

SAMSUNG

ELECTRONICS

Approval

TO : General

DATE : Mar. 06. 2006

SAMSUNG TFT-LCD

MODEL NO. : LTV350QV-F04

Any Modification of Spec is not allowed without SEC's permission.

Approved by : S.C. OH

LCD DIVISION

Samsung Electronics Co., Ltd.



Revision History

Date	Rev. No.	Page	Summary
Mar.06.2006	000		Rev.000 was issued.

Contents

General Description	-----	(4)
1. Absolute Maximum Ratings	-----	(5)
1.1 Absolute Ratings Of Environment		
1.2 Electrical Absolute Ratings		
2. Optical Characteristics	-----	(7)
3. Electrical Characteristics	-----	(11)
3.1 TFT-LCD Module		
3.2 Back-light Unit		
4. Block Diagram	-----	(13)
4.1 TFT-LCD Module with Back Light Unit		
5. Input Terminal Pin Assignment	-----	(14)
5.1 Input Signal & Power		
5.2 Input Signal, Basic Display Colors and Gray Scale of Each Colors		
6. Operation Specifications	-----	(16)
6.1 Serial Peripheral Interface		
6.2 Data Format for 24bit RGB Interface		
6.3 24bit RGB Interface Timing		
6.4 Electrical Specifications		
7. Command List & Instruction Descriptions	-----	(21)
7.1 Command List		
7.2 Instruction Descriptions		
8. Power On/Off Sequence	-----	(22)
8.1 Power On Sequence		
8.2 Power Off Sequence		
9. Reliability Test Result	-----	(26)
9.1 Condition		
9.2 Judgement		
10. Outline Dimension	-----	(28)
11. Packing	-----	(29)
12. Marking & Others	-----	(30)
13. General Precaution	-----	(31)
13.1 Handling		
13.2 Storage		
13.3 Operation		
13.4 Others		

General Description

* Description

LTV350QV-F04 is a TMR(Transmissive with Micro Reflective) type color active matrix TFT (Thin Film Transistor) liquid crystal display (LCD) that uses amorphous silicon TFT as a switching devices. This model is composed of a TFT-LCD module, a driver circuit and a back-light unit.

The resolution of a 3.5" contains 320RGBx240 dots and can display up to 16.7M colors.

* Features

- Transmissive with Micro Reflective type and back-light with six LEDs are available.
- TN(Twisted Nematic) mode.
- Line inversion mode with stripe type.
- 24bit RGB Interface + Serial Peripheral Interface(SPI)
- SYNC(Vsync, Hsync, Dotclk) mode
- Gate Driver IC embeded on Panel(Double ASG)

* Applications

- Display terminals for DSC(Digital Still Camera), PMP(Portable Multimedia Player) application products.

* General information

Items	Specification	Unit	Note
Display area	70.08(H) x 52.56(V)	mm	-
Driver element	a-Si TFT active matrix	-	-
Display colors	16.7M	colors	-
Number of pixels	320RGB(H) x 240(V)	dot	-
Pixel arrangement	stripe type	-	-
Pixel pitch	0.219(H) x 0.219(V)	mm	-
Display mode	Normally White	-	-
Viewing direction	6	o'clock	-

* Mechanical information

Item	Min.	Typ.	Max.	Unit	Note	
Module size	Horizontal(H)	76.70	76.90	77.10	mm	-
	Vertical(V)	63.70	63.90	64.10	mm	(1)
	Depth(D)	2.95	3.15	3.35	mm	(1)
Weight	-	32	37	g	-	

Note (1) Not include FPC

Refer to the Outline Dimension in the "10.Outline Dimension" for further information.

1. Absolute Maximum Ratings

1.1 Environment

ITEM	MIN	MAX	REMARK
Storage Temperature	-30℃	70℃	Note(1)
Operating Temperature	-20℃	60℃	Note(2) (3)

Note(1) 90%RH maximum humidity, 60℃ maximum wet-bulb temperature

- (2) When operated at a temperature lower than 0℃, the LCD worked slowly and the screen appeared low-contrast images due to the characteristics of LC(Liquid Crystal).
- (3) If any fixed pattern is displayed on LCD for minutes, image-sticking phenomenon may occur.

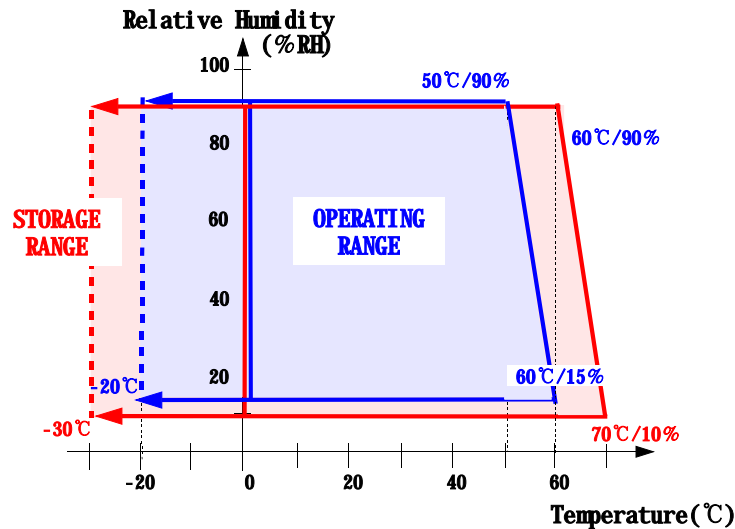

Temperature & Humidity Graph at Absolute Environment

1.2 Electrical Absolute Ratings

(1) TFT-LCD Module

(Ta = 25 ± 2°C, V_{SS}=GND=0)

Characteristics	Symbol	Min.	Max.	Unit	Note
Digital supply voltage	V _{DD}	-0.3	5.0	V	-
Analog supply voltage	AVDD	-0.3	7.0	V	-
Gate On voltage	V _{GH}	-0.3	22.0	V	-
Gate Off voltage	V _{GL}	-18.5	0.3	V	-

(2) Back-Light Unit

(Ta = 25 ± 2°C)

Item	Symbol	Min.	Max.	Unit.	Note
Current	I _B		25	mA	(1)

Note (1) Permanent damage to the device may occur if maximum values are exceeded or reverse voltage is loaded.

Functional operation should be restricted to the conditions described under normal operating conditions.

2. Optical Characteristics

The following items are measured under stable conditions. The optical characteristics should be measured in a dark room or equivalent state with the methods shown in Note (1).

Measuring equipment: LCD-5000, BM-5A, BM-7, PR-650, EZ-Contrast

($T_a = 25 \pm 2^\circ\text{C}$, $V_{CC} = V_{CI} = 3.3\text{V}$, $I_B = 20\text{mA}$)

Item	Symbol	Condition	Min.	Typ.	Max.	Unit	Note
Contrast ratio (Center point)	C/R		150	300	-	-	(2) BM-5A
Luminance of white (Center point)	YL	NOTE (1)	190	250	-	cd/m ²	(3) BM-5A
Response time	Rising:Tr	Tr+Tf	-	25	30	msec	(4) BM-7
	Falling:Tf						
Color chromaticity (CIE 1931)	White	Wx	Normal Viewing Angle	0.27	0.32	0.37	-
		Wy					
	Red	Rx	B/L On	0.56	0.61	0.66	
		Ry					
	Green	Gx	B/L On	0.28	0.33	0.38	
		Gy					
	Blue	Bx	B/L On	0.09	0.14	0.19	
		By					
Viewing angle	Hor.	θ_L	$C/R \geq 10$	55	60	Degrees	(6) Ez-Contrast
		θ_R					
	Ver.	ϕ_H	B/L On	45	50		
		ϕ_L					

Note (1) Test Equipment Setup

After stabilizing and leaving the panel alone at a given temperature for 30 min , the measurement should be executed. Measurement should be executed in a stable, windless, and dark room. 30 min after lighting the back-light. This should be measured in the center of screen.

Environment condition : $T_a = 25 \pm 2 \text{ } ^\circ\text{C}$

Back-Light On condition

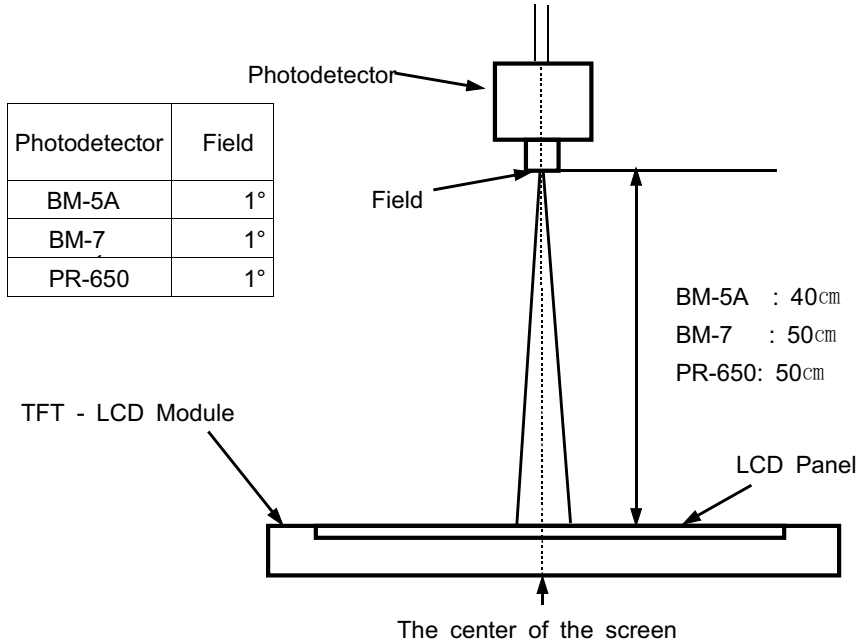

Back-Light Off condition

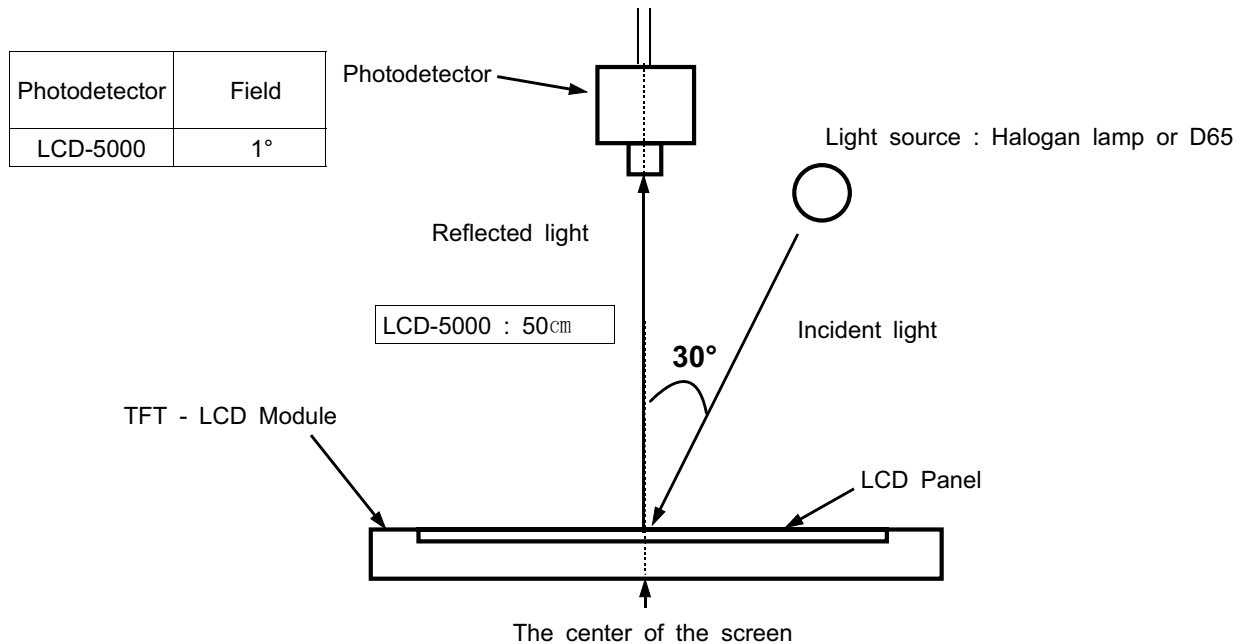

Optical Measuring Equipment Setup

Note (2) Definition of Contrast Ratio (C/R) : Ratio of gray max (Gmax) & gray min (Gmin) at the center point

$$CR = \frac{G_{max}}{G_{min}}$$

* Gmax : Luminance with all pixels white
* Gmin : Luminance with all pixels black

Note (3) Definition of Luminance of White : Luminance of white at the center point

Note (4) Definition of Response time : Sum of Tr ,Tf

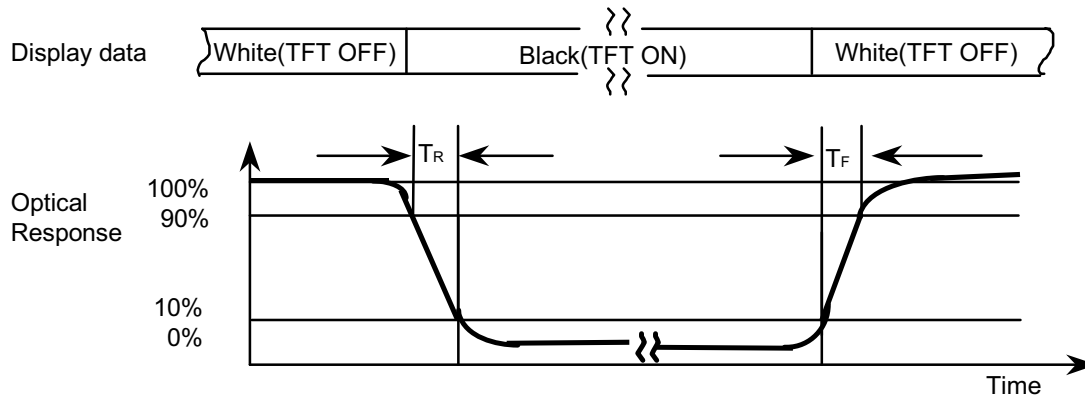

Note (5) Definition of Color Chromaticity (CIE 1931)

Color coordinate of white & red, green, blue at center point.

Note (6) Definition of Viewing Angle : Viewing angle range ($CR \geq 10$)

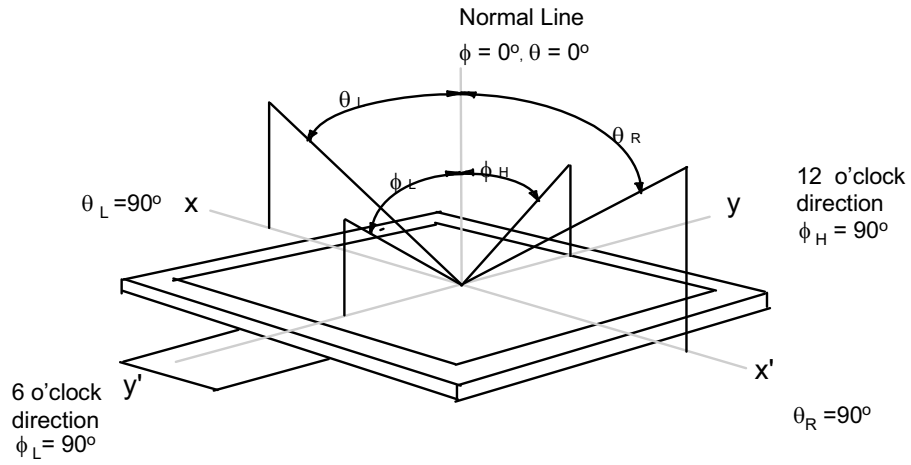

3. Electrical Characteristics

3.1 TFT-LCD Module

 $T_a = 25 \pm 2^\circ\text{C}$

Characteristics		Symbol	Min.	Typ.	Max.	Unit	Note
Digital supply voltage		V_{DD}	2.5	3.3	3.6	V	-
Analog supply voltage		AVDD	4.8	4.9	5.0	V	-
Gate On voltage		V_{GH}	17.0	18.0	19.0	V	#1
Gate Off voltage		V_{GL}	-11	-10	-9	V	-
Vcom High voltage		VcomH		3.68			
Vcom Low voltage		VcomL		0.4			
Power Dissipation	Full	P_{FULL}		40	60	mW	#2,#3
Frame frequency		f_{Frame}	60	75	90	Hz	-
Dot Clock		DOTCLK	-	-	30.0	MHz	-
Serial Clock		SCL	-	-	16.0	MHz	-

Note #1. $|V_{GH} - (V_{GL} \times 0.7)| = 25V$

Note #2. $V_{CC} = 3.3V$, $f_{Frame} = 75Hz$, $DOTCLK = 7.0MHz$

Note #3. Dissipation current check pattern

► 0 Gray black pattern

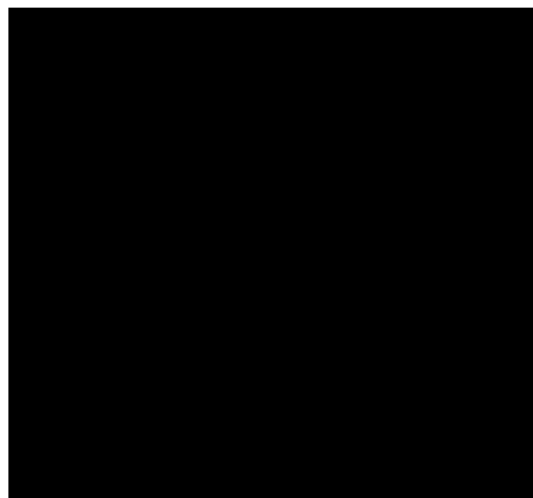

3.2 Back-Light unit

The back-light system is an edge-lighting type with **six** white LED(Light Emitting Diode)s.
 (Ta=25 ± 2°C)

Item	Symbol	Min.	Typ.	Max.	Unit	Note
Current	I_B	-	20	-	mA	(1)
Power Consumption	P_{BL}	-	400	-	mW	(2)

Note (1) Six LEDs serial type.

(2) Where $I_B = 20\text{mA}$, $V_B = P_{BL} / I_B$

■ Ambient Temperature vs. Allowable Forward Current

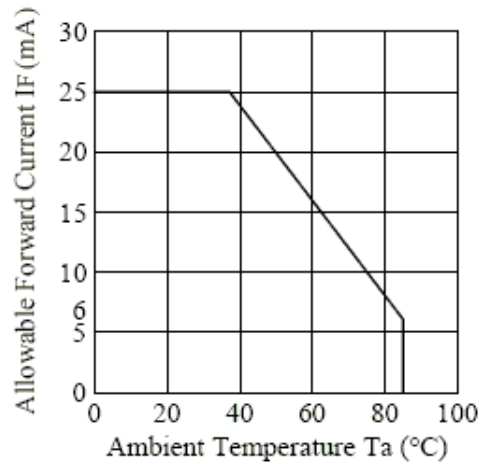

4. Block Diagram

4.1 TFT-LCD Module (Interface System Structure) with Back Light Unit

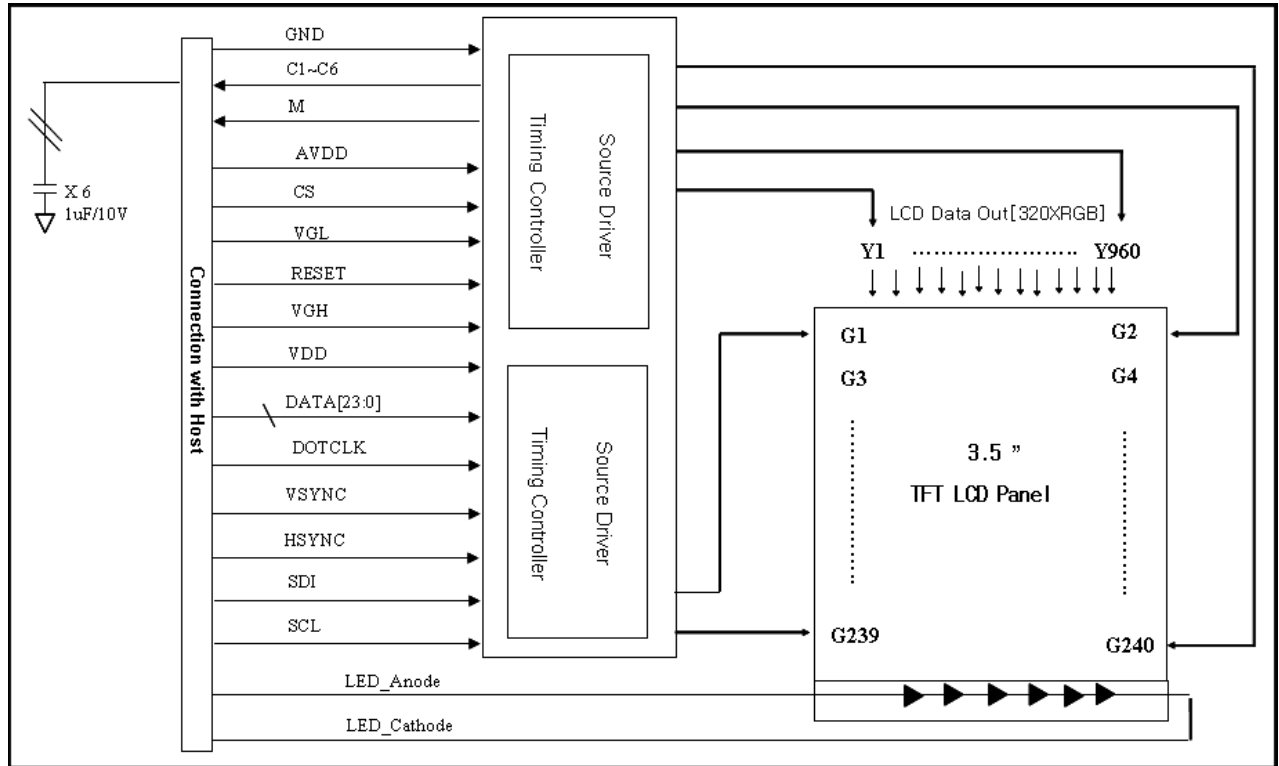

5. Input Terminal Pin Assignment

5.1 Input Signal & Power (Connector type : 54Pin / 0.5mm pitch / Bottom contact)

- kyocera elco : 6240 series

No	Symbol	Description	I/O	No	Symbol	Description	I/O
1,2	LED_Cathode	LED_Cathode	I	26	DATA14	Green data	I
3,4	LED_Anode	LED_Anode	I	27	DATA15	Green data(MSB)	I
5	C6(1uF,10V)	Stable Capacitor connection	O	28	DATA16	Red data(LSB)	I
6	C5(1uF,10V)	Stable Capacitor connection	O	29	DATA17	Red data	I
7	M	The signal to generate Vcom	O	30	DATA18	Red data	I
8	RESET	Reset	I	31	DATA19	Red data	I
9	CS	Chip Select	I	32	DATA20	Red data	I
10	SCL	Serial Clock	I	33	DATA21	Red data	I
11	SDI	Serial Data	I	34	DATA22	Red data	I
12	DATA0	Blue data(LSB)	I	35	DATA23	Red data(MSB)	I
13	DATA1	Blue data	I	36	HSYNC	Horizontal Synchronous Signal	I
14	DATA2	Blue data	I	37	VSYNC	Vertical Synchronous Signal	I
15	DATA3	Blue data	I	38	DOTCLK	Data Clock	I
16	DATA4	Blue data	I	39, 40	AVDD	Vanalog	I
17	DATA5	Blue data	I	41, 42	VDD	Vdigital	I
18	DATA6	Blue data	I	43	C4(1uF,10V)	Stable Capacitor connection	O
19	DATA7	Blue data(MSB)	I	44, 45	VGL	Vgoff voltage	I
20	DATA8	Green data(LSB)	I	46	C3(1uF,10V)	Stable Capacitor connection	O
21	DATA9	Green data	I	47	VGH	Vgon Voltage	I
22	DATA10	Green data	I	48	C2(1uF,10V)	Stable Capacitor connection	O
23	DATA11	Green data	I	49	C1(1uF,10V)	Stable Capacitor connection	O
24	DATA12	Green data	I	50, 51	VCOM	VCOM	I
25	DATA13	Green data	I	52,53,54	GND	Ground	I

5.2 Input Signal, Basic Display Colors and Gray Scale of Each Colors

COLOR	DISPLAY	DATA SIGNAL																				GRAY SCALE LEVEL				
		RED							GREEN							BLUE										
		R0	R1	R2	R3	R4	R5	R6	R7	G0	G1	G2	G3	G4	G5	G6	G7	B0	B1	B2	B3		B4	B5	B6	B7
BASIC COLOR	BLACK	0	0	0	0	0	0	0	0	0	0	0	0	0	0	0	0	0	0	0	0	0	0	0	-	
	BLUE	0	0	0	0	0	0	0	0	0	0	0	0	0	0	0	0	1	1	1	1	1	1	1	1	-
	GREEN	0	0	0	0	0	0	0	0	1	1	1	1	1	1	1	1	0	0	0	0	0	0	0	0	-
	CYAN	0	0	0	0	0	0	0	0	1	1	1	1	1	1	1	1	1	1	1	1	1	1	1	1	-
	RED	1	1	1	1	1	1	1	1	0	0	0	0	0	0	0	0	0	0	0	0	0	0	0	0	-
	MAGENTA	1	1	1	1	1	1	1	1	0	0	0	0	0	0	0	0	1	1	1	1	1	1	1	1	-
	YELLOW	1	1	1	1	1	1	1	1	1	1	1	1	1	1	1	1	0	0	0	0	0	0	0	0	-
	WHITE	1	1	1	1	1	1	1	1	1	1	1	1	1	1	1	1	1	1	1	1	1	1	1	1	-
GRAY SCALE OF RED	BLACK	0	0	0	0	0	0	0	0	0	0	0	0	0	0	0	0	0	0	0	0	0	0	0	R0	
	DARK ↑	1	0	0	0	0	0	0	0	0	0	0	0	0	0	0	0	0	0	0	0	0	0	0	R1	
		0	1	0	0	0	0	0	0	0	0	0	0	0	0	0	0	0	0	0	0	0	0	0	R2	
		:	:	:	:	:	:	:	:	:	:	:	:	:	:	:	:	:	:	:	:	:	:	:	:	R3~R252
		:	:	:	:	:	:	:	:	:	:	:	:	:	:	:	:	:	:	:	:	:	:	:	:	
	LIGHT ↓	1	0	1	1	1	1	1	1	0	0	0	0	0	0	0	0	0	0	0	0	0	0	0	R253	
		0	1	1	1	1	1	1	1	0	0	0	0	0	0	0	0	0	0	0	0	0	0	0	R254	
	RED	1	1	1	1	1	1	1	1	0	0	0	0	0	0	0	0	0	0	0	0	0	0	0	R255	
GRAY SCALE OF GREEN	BLACK	0	0	0	0	0	0	0	0	0	0	0	0	0	0	0	0	0	0	0	0	0	0	0	G0	
	DARK ↑	0	0	0	0	0	0	0	0	1	0	0	0	0	0	0	0	0	0	0	0	0	0	0	G1	
		0	0	0	0	0	0	0	0	0	1	0	0	0	0	0	0	0	0	0	0	0	0	0	G2	
		:	:	:	:	:	:	:	:	:	:	:	:	:	:	:	:	:	:	:	:	:	:	:	G3~G252	
		:	:	:	:	:	:	:	:	:	:	:	:	:	:	:	:	:	:	:	:	:	:	:		
	LIGHT ↓	0	0	0	0	0	0	0	0	1	0	1	1	1	1	1	1	0	0	0	0	0	0	0	G253	
		0	0	0	0	0	0	0	0	0	1	1	1	1	1	1	1	0	0	0	0	0	0	0	G254	
	GREEN	0	0	0	0	0	0	0	0	1	1	1	1	1	1	1	1	0	0	0	0	0	0	0	G255	
GRAY SCALE OF BLUE	BLACK	0	0	0	0	0	0	0	0	0	0	0	0	0	0	0	0	0	0	0	0	0	0	0	B0	
	DARK ↑	0	0	0	0	0	0	0	0	1	0	0	0	0	0	0	0	0	0	0	0	0	0	0	B1	
		0	0	0	0	0	0	0	0	0	1	0	0	0	0	0	0	0	0	0	0	0	0	0	B2	
		:	:	:	:	:	:	:	:	:	:	:	:	:	:	:	:	:	:	:	:	:	:	:	B3~B252	
		:	:	:	:	:	:	:	:	:	:	:	:	:	:	:	:	:	:	:	:	:	:	:		
	LIGHT ↓	0	0	0	0	0	0	0	0	1	0	1	1	1	1	1	1	0	0	0	0	0	0	0	B253	
		0	0	0	0	0	0	0	0	0	1	1	1	1	1	1	1	0	0	0	0	0	0	0	B254	
	BLUE	0	0	0	0	0	0	0	0	1	1	1	1	1	1	1	1	0	0	0	0	0	0	0	B255	

Note) Definition of Gray :

Rn : Red Gray, Gn : Green Gray, Bn : Blue Gray (n = Gray level)

Input Signal : 0 = Low level voltage, 1 = High level voltage

6. Operation Specifications

6.1 Serial Peripheral Interface

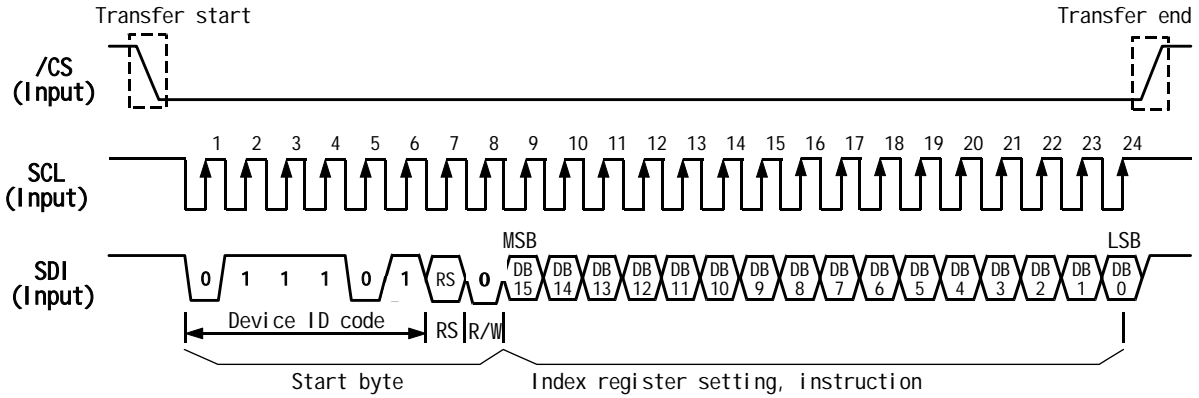

(Note) RS="0": Index data
 RS="1": Instruction data

6.2 Data Format for 24bit RGB Interface

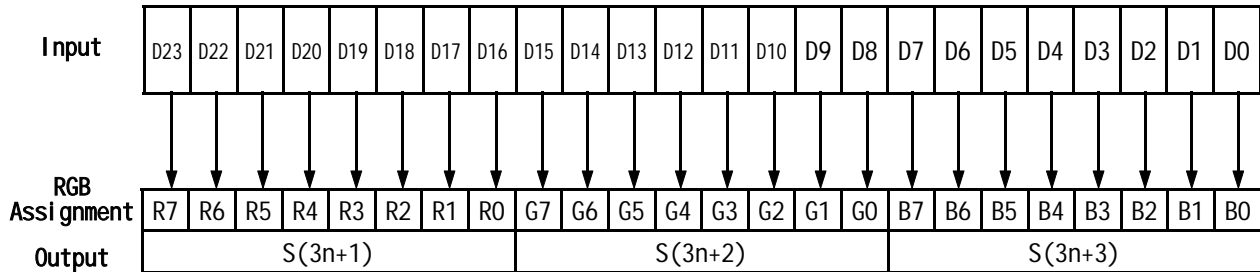

6.3 24bit RGB Interface Timing
- SYNC mode

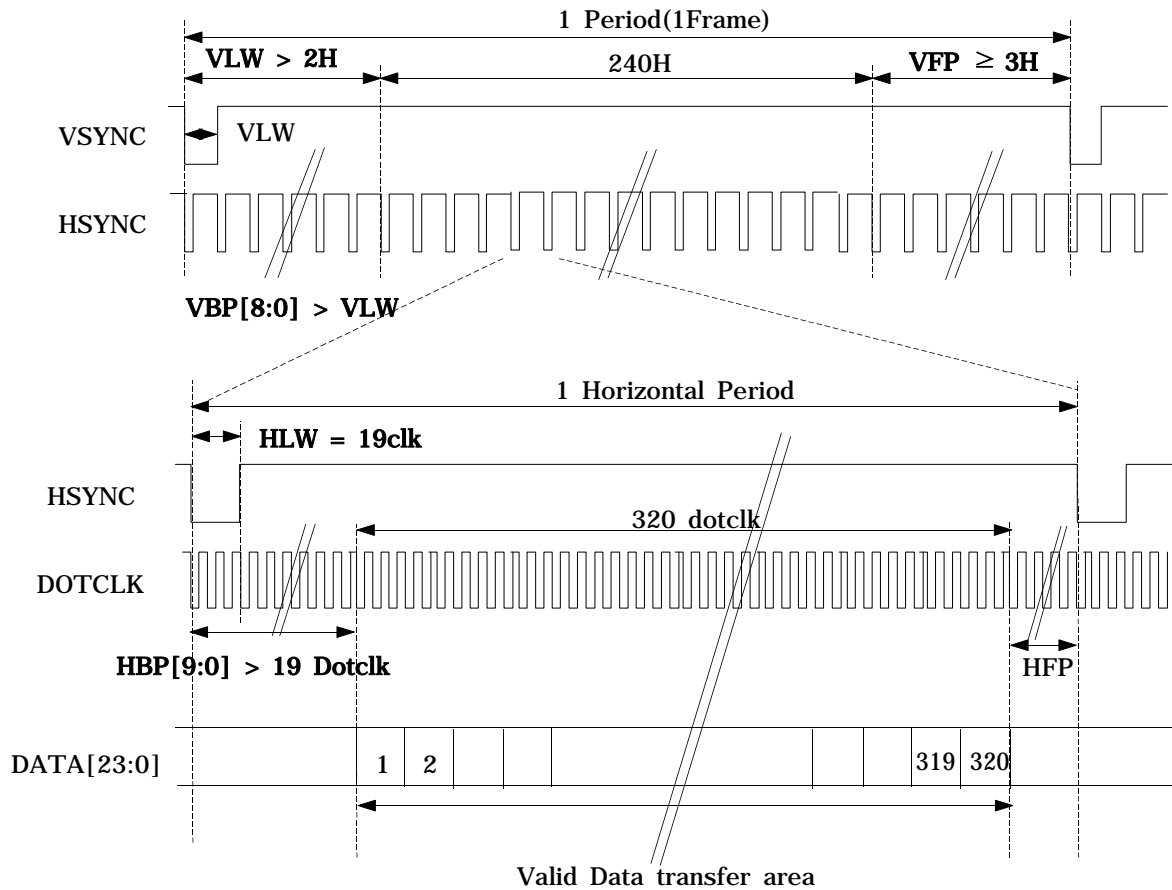

$$* \text{DOTCLK} = f_{\text{frame}} \times (240 + VBP + VFP) \times (320 + HBP + HFP)$$

$$= 75\text{Hz} \times (240 + VBP + VFP) \times (320 + HBP + HFP)$$

$$* 3H \leq VFP$$

$$* HBP > HLW$$

$$* VBP > VLW$$

$$* 15\text{clk} < HLW < 20\text{clk}$$

$$* VLW > HLW$$

Note 1. Polarity register setting : VPL = 0, HPL = 0, DPL=0

2. The rising edge of DOTCLK is used to fetch display data

6.4 Electrical Specifications

a. RGB Data Interface Characteristics

(T_A = - 40 to +85°C)

Characteristic	Symbol	24bit RGB Interface		Unit
		Min	Max	
DOTCLK cycle time	tDCYC	100	-	ns
DOTCLK rise/fall time	tR,tF	-	2	
DOTCLK Pulse width high	tDCHW	50	-	
DOTCLK Pulse width low	tDCLW	50	-	
SYNC setup time	tSYS	30	-	
SYNC hold time	tSYH	30	-	
PD data setup time	tPDS	30	-	
PD data hold time	tPDH	30	-	

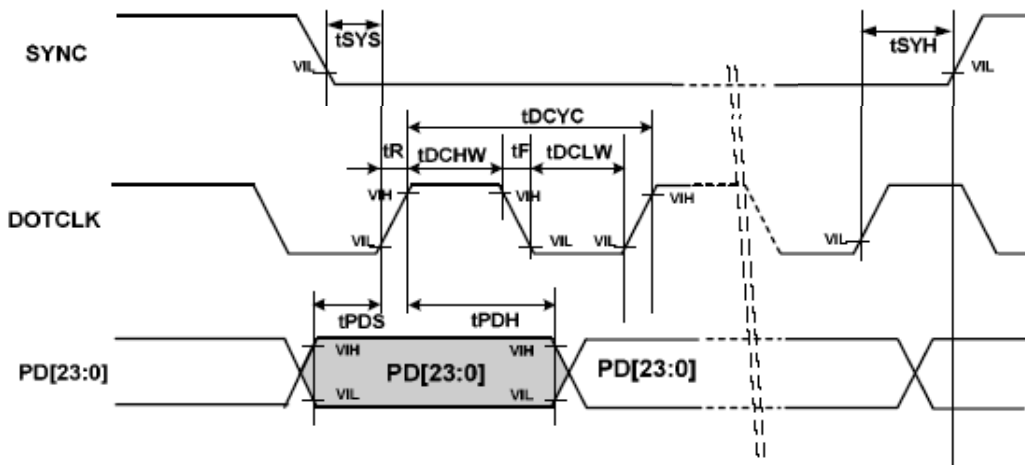

AC Characteristics

b. Clock Synchronized Serial Mode Characteristics

(T_A = - 40 to +85°C)

Characteristic	Symbol	Min	Max	Unit
Serial clock cycle time	tscyc	100	-	ns
Serial clock rise/fall time	tR,tF	-	2	
Pulse width high for write	tSCHW	30	-	
Pulse width high for read	tSCHR	50	-	
Pulse width low for write	tSCLW	30	-	
Pulse width low for read	tSCLR	50	-	
Chip Select setup time	tCSS	20	-	
Chip Select hold time	tCSH	50	-	
Serial input data setup time	tSIDS	30	-	
Serial input data hold time	tSIDH	30	-	
Serial output data delay time	tSODD	-	100	
Serial output data hold time	tSODH	5	-	

c. Reset Timing Characteristics

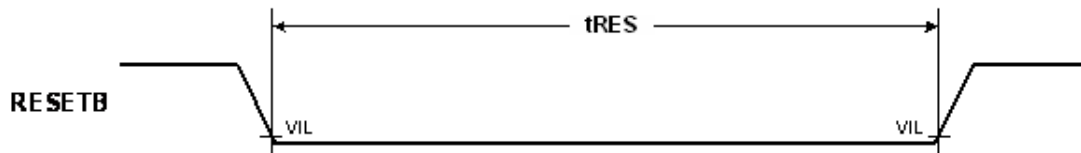

***NOTE.** Reset low pulse width shorter than 1us do not make reset. It means undesired short pulse such as glitch, bouncing noise or electrostatic discharge do not cause irregular system reset. Please refer to the table below.

(T_A = - 40 to +85°C)

Characteristic	Symbol	Min	Max	Unit
Reset low pulse width	tRES	10	-	us

Table 1. Reset Operation regarding tRES Pulse Width

tRES Pulse	Action
Shorter than 2 us	No reset
Longer than 10 us	Reset
Between 2 us and 10 us	Not determined

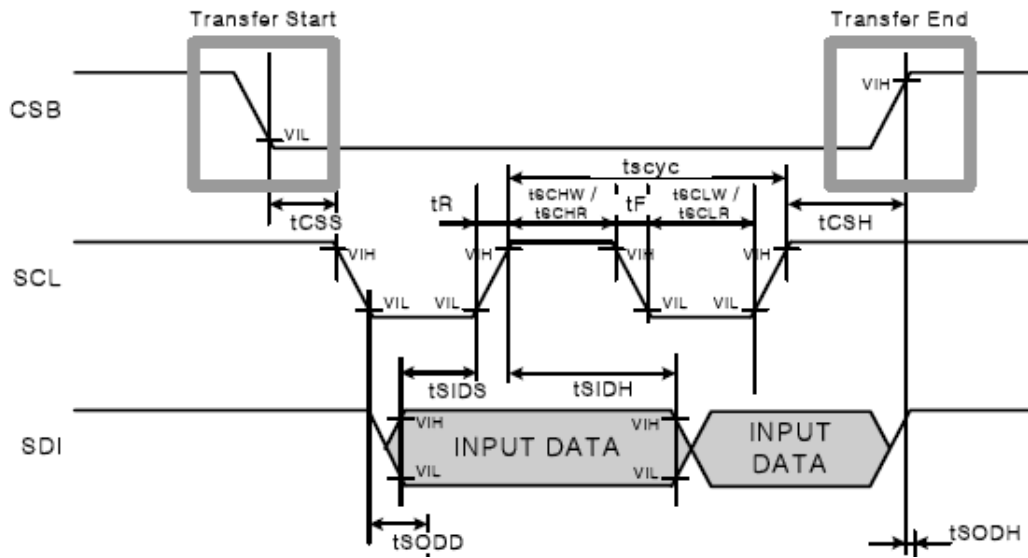

AC Characteristics(SPI Mode)

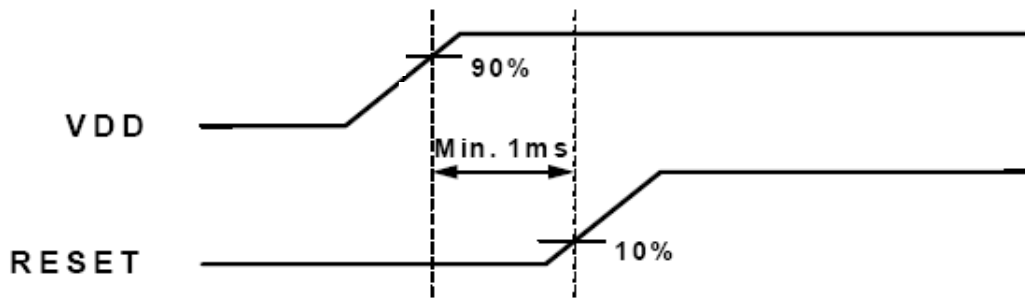

AC Characteristics(RESET timing)

7. Command List & Instruction Descriptions

7.1 Command List

Refer to the Appendix 1: S6F2002 IC Specification

7.2 Instruction Descriptions

Refer to the Appendix 1: S6F2002 IC Specification

8. Power On/Off Sequence

The power on/off sequence should be as the below.

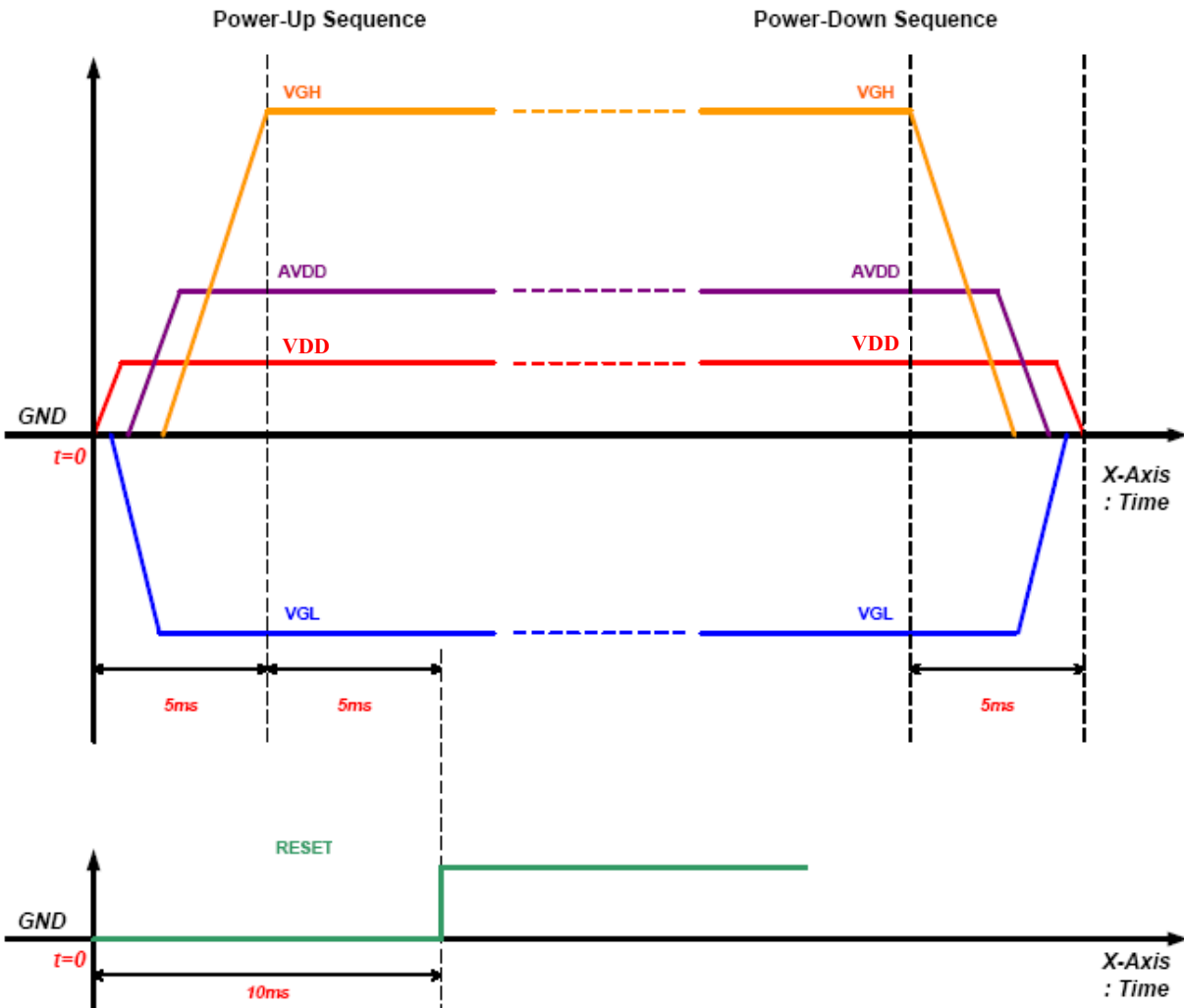

Note 1. VDD, AVDD, VGH and VGL could be turned on/off at the same time within the designated period(5ms)

Note 2. RESET timing should be observed for the stable operation of the driver.

Note 3. During the Screen save mode or the Power save mode or the Sleep mode, all of the power to the LCD Module should not be supplied.

The Power on/off sequence should be same as the described above while mode is changed to prevent damage of the LCD Panel.

8.1 Power On Sequence

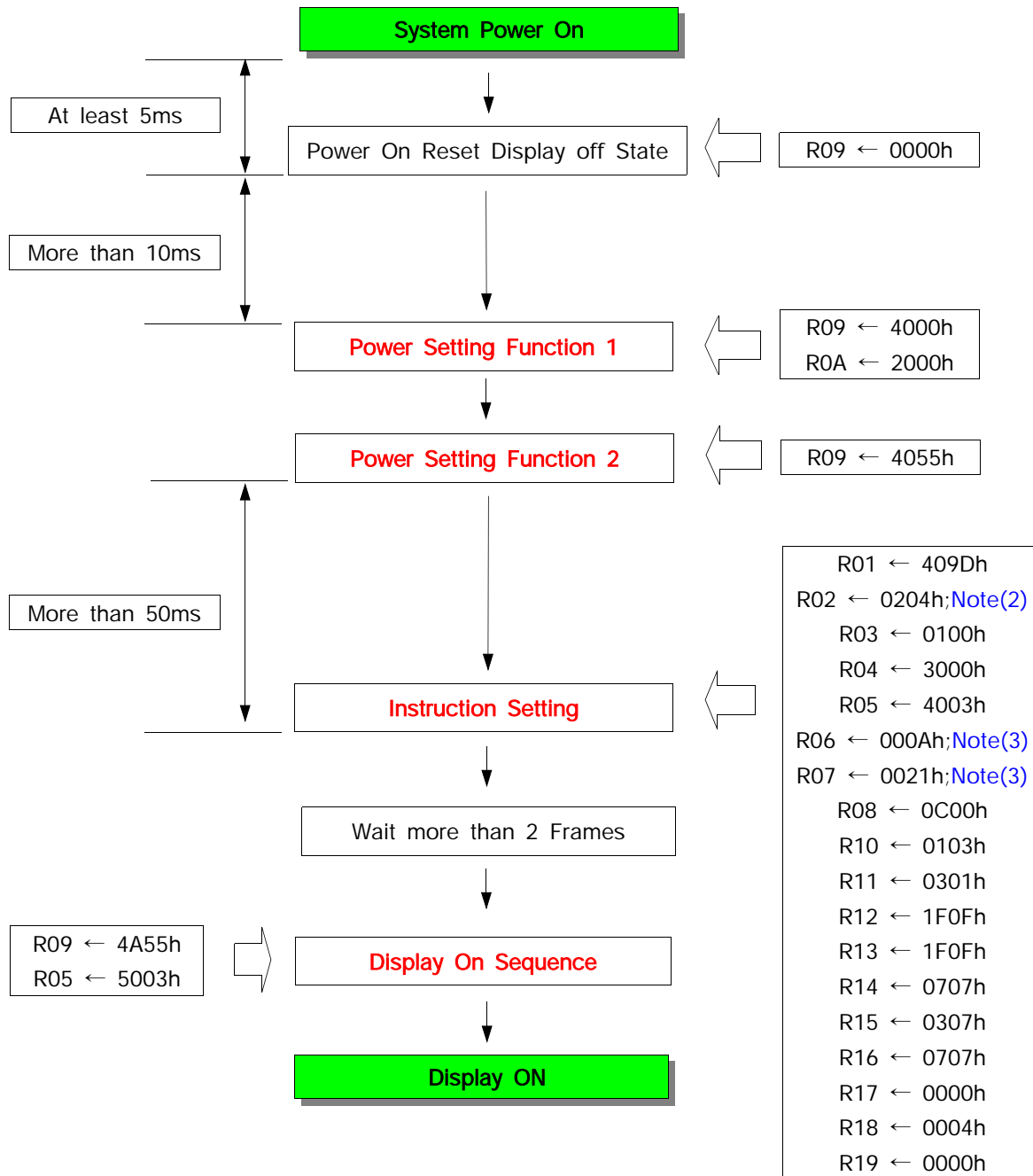

< Note (1) >

- Register R02 determines Data format

(R02H)

IB15	IB14	IB13	IB12	IB11	IB10	IB9	IB8	IB7	IB6	IB5	IB4	IB3	IB2	IB1	IB0
0	0	0	0	0	0	1	0	DF1	DF0	0	0	0	1	0	0

- DF Bits Setting

DF1	DF0	Data Format	R02H
0	0	RGB RGB	0204
0	1	RGBX RGBX	0244
1	0	XRGB XRGB	0284
1	1	Setting Inhibited	

< Note (2) >

- Register R06, R07 determine Vsync Backporch(R06) & Hsync Backporch period(R07)

- Backporch limit

(1) 15clk < Hsync Backporch < 1024clk

(2) 3line < Vsync Backporch < 512line

(R06H)

IB15	IB14	IB13	IB12	IB11	IB10	IB9	IB8	IB7	IB6	IB5	IB4	IB3	IB2	IB1	IB0
0	0	0	0	0	0	0	VBP8	VBP7	VBP6	VBP5	VBP4	VBP3	VBP2	VBP1	VBP0

(R07H)

IB15	IB14	IB13	IB12	IB11	IB10	IB9	IB8	IB7	IB6	IB5	IB4	IB3	IB2	IB1	IB0
0	0	0	0	0	0	0	HBP8	HBP7	HBP6	HBP5	HBP4	HBP3	HBP2	HBP1	HBP0

8.2 Power Off Sequence

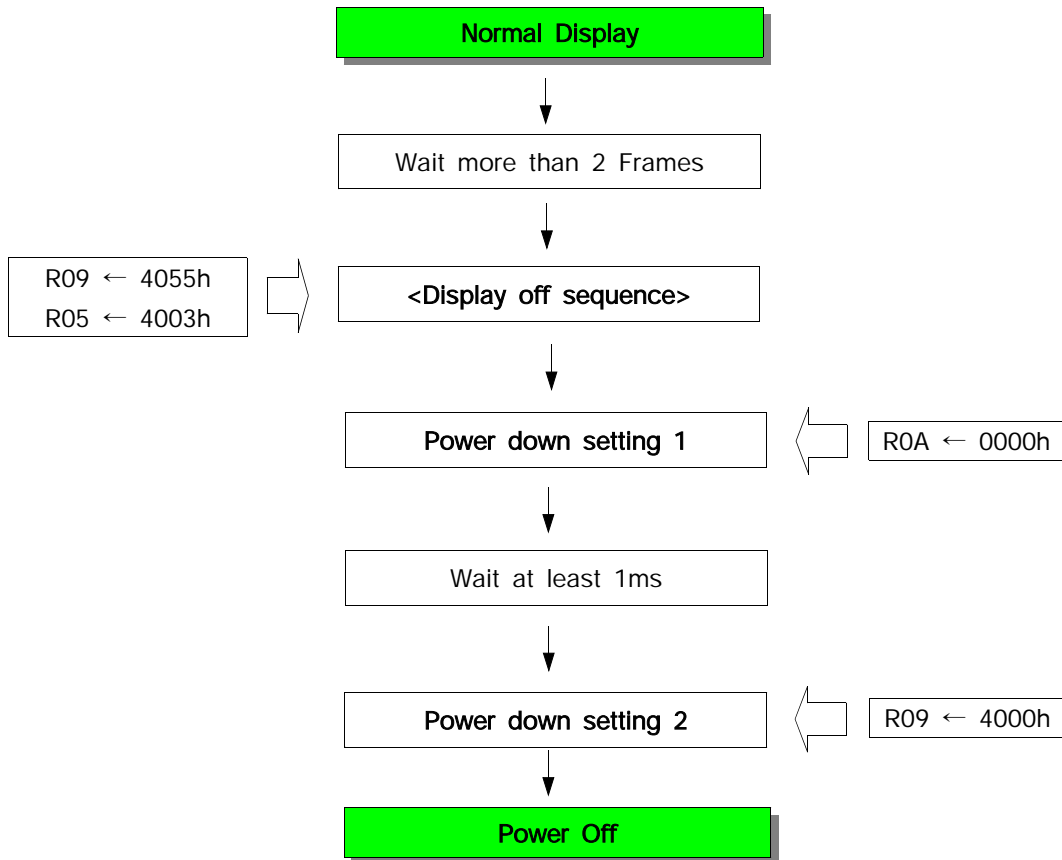

9. Reliability Test Result

9.1 Condition

ITEM	CONDITION	REMARK	Test Result
High Temperature Operating Life-test	60°C, 240HR		PASS
Low Temperature Operating Life-test	-20°C, 240HR		PASS
Temperature Humidity Bias test	50°C 90%RH, 240HR		PASS
Temperature Cycle ON/OFF test	-30°C ⇔ 70°C ON/OFF, 5CY	Note(1)	PASS
High Temperature Storage test	70°C, 240HR		PASS
Low Temperature Storage test	-30°C, 240HR		PASS
Wet High Temperature Storage test	60°C 90%RH, 240HR		PASS
Thermal Shock test	-30°C ⇔ 70°C, 100CY	Note(2)	PASS
Electro-Static Discharge test	CONTACT: ±4 kV, 20times A I R: ±8 kV, 20times	Note(3)	PASS
Box Vibration test	RANDOM 0.74Grms, 1HR/Y axis(SMALL BOX)	Note(4)	PASS
Box Drop test	1 Corner 3 Edges 6 faces, 66cm(MEDIUM BOX)		PASS

Note(1) ON Time over 10 seconds, OFF Time under 10 seconds

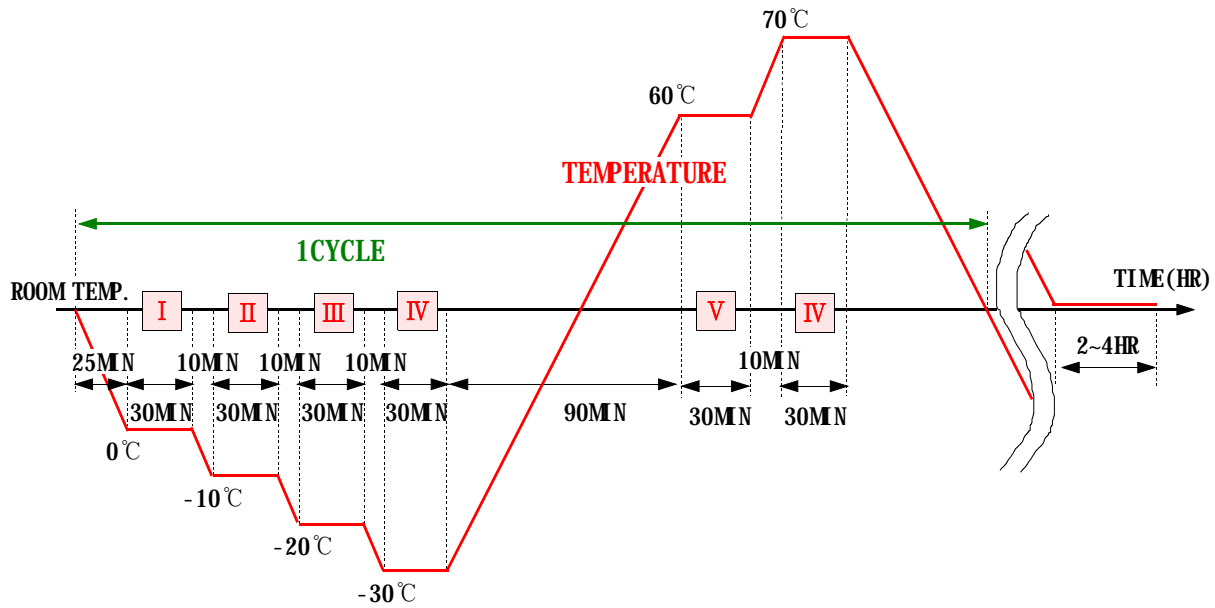

Temperature Cycle Transit Condition

Note(2) STORAGE

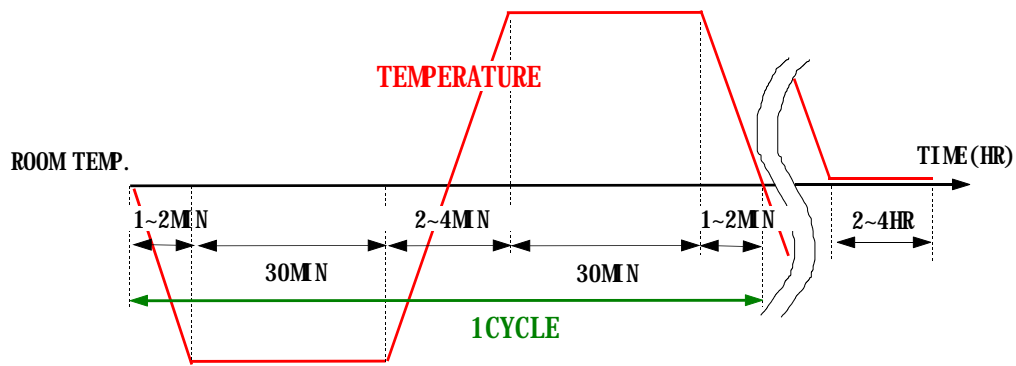

Thermal Shock Transit Condition

Note(3) Main-LCD, 5 times to every 4 corners of active area

Note(4) Basic transportation by common carrier environmental,
514.4 MIL-STD-810E

OVERAL L RMS LEVEL	BREAK POINT					
	FRQUEN CY	PSD VALUE	FRQUEN CY	PSD VALUE	FRQUEN CY	PSD VALUE
0.74G	10Hz	0.00650	121Hz	0.00300	340Hz	0.00003
	20Hz	0.00650	200Hz	0.00300	500Hz	0.00015
	120Hz	0.00020	240Hz	0.00150	-	-

9.2 Judgement

- > Main LCD should work under the normal condition.
- > After the temperature and humidity test,
the luminance and CR(Contrast Ratio) should not be changed over 50%
compared with those before the test.

NO	PIN NAME	NO	PART NAME	CODE NO	SPECIFICATION	Q'TY	SPEC NO	REMARK
1	LED_Cathode							
2	LED_Cathode							
3	LED_Anode							
4	LED_Anode							
5	C6							
6	C5							
7	M							
8	RESET							
9	CS							
10	SCL							
11	SDI							
12	DATA0							
13	DATA1							
14	DATA2							
15	DATA3							
16	DATA4							
17	DATA5							
18	DATA6							
19	DATA7							
20	DATA8							
21	DATA9							
22	DATA10							
23	DATA11							
24	DATA12							
25	DATA13							
26	DATA14							
27	DATA15							
28	DATA16							
29	DATA17							
30	DATA18							
31	DATA19							
32	DATA20							
33	DATA21							
34	DATA22							
35	DATA23							
36	HSYNC							
37	VSYNC							
38	DOTCLK							
39	AVDD							
40	AVDD							
41	VDD							
42	VDD							
43	C4							
44	VGL							
45	VGL							
46	C3							
47	VGH							
48	C2							
49	C1							
50	VCOM							
51	VCOM							
52	GND							
53	GND							
54	GND							

10. Outline Dimension

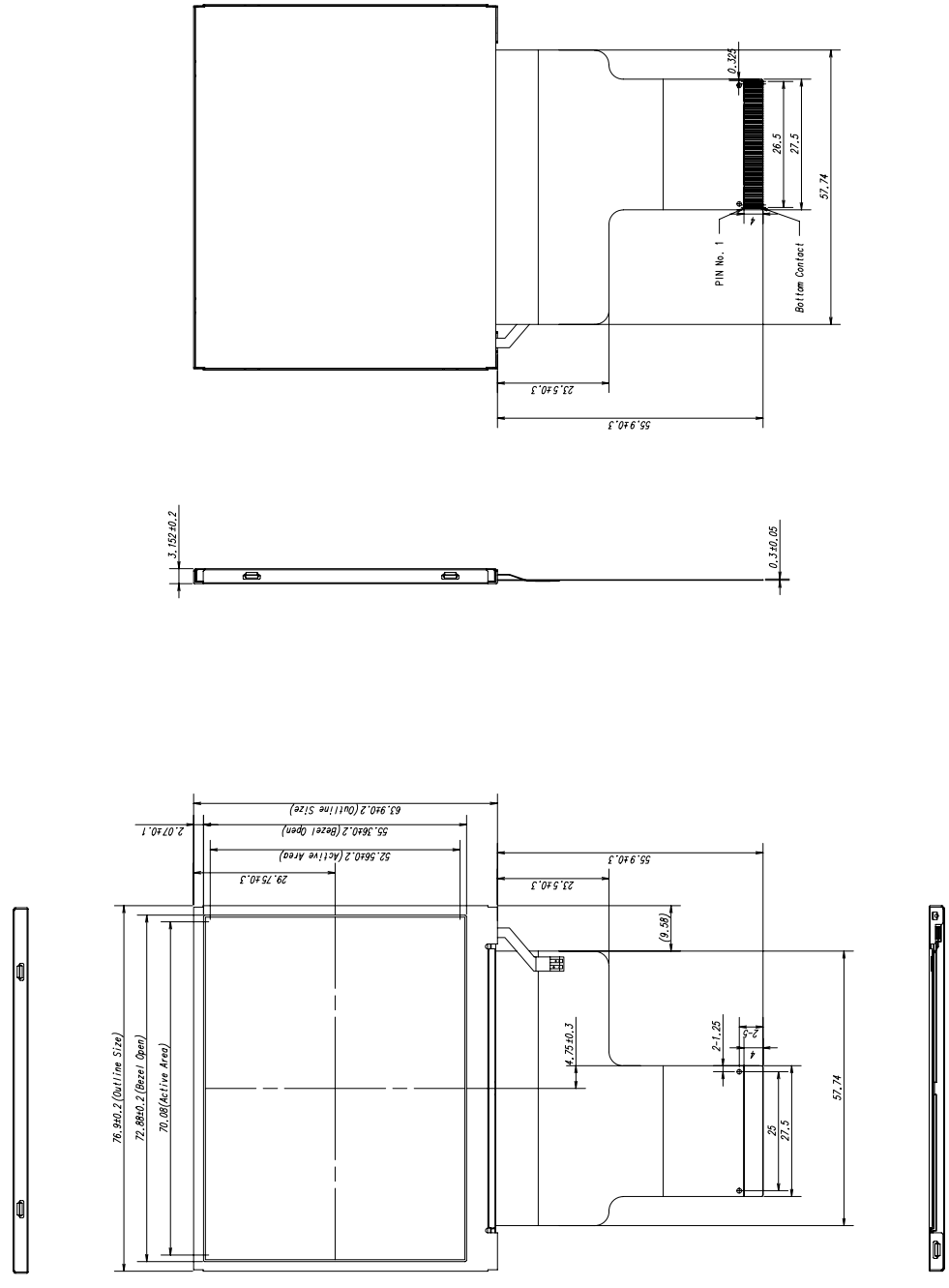

GENERAL TOLERANCE		REVISION		DESCRIPTION OF REVISION		CHECKED BY						
STEP	LEVEL 1	LEVEL 2	LEVEL 3	UNIT	DATE	DRW'N BY	DES'G'D BY	CHK'D BY	APP'D BY	REASON	MODEL NAME	CHK'D BY
0 < X ≤ 4	±0.05	±0.1	±0.2	mm						LTV350QV-F04		
4 < X ≤ 16	±0.06	±0.15	±0.3	SCALE		W, H, K, M	S, H, LEE	Y, B, CHU		Out-Dimension		
16 < X ≤ 64	±0.12	±0.25	±0.5	TOLERANCE		LEVEL 2	06.03.06	06.03.06	06.03.06			
64 < X ≤ 256	±0.25	±0.4	±0.8	LEVEL 2								
SAMSUNG ELECTRONICS												
											CODE NO.	VER. 1000

11. Packing

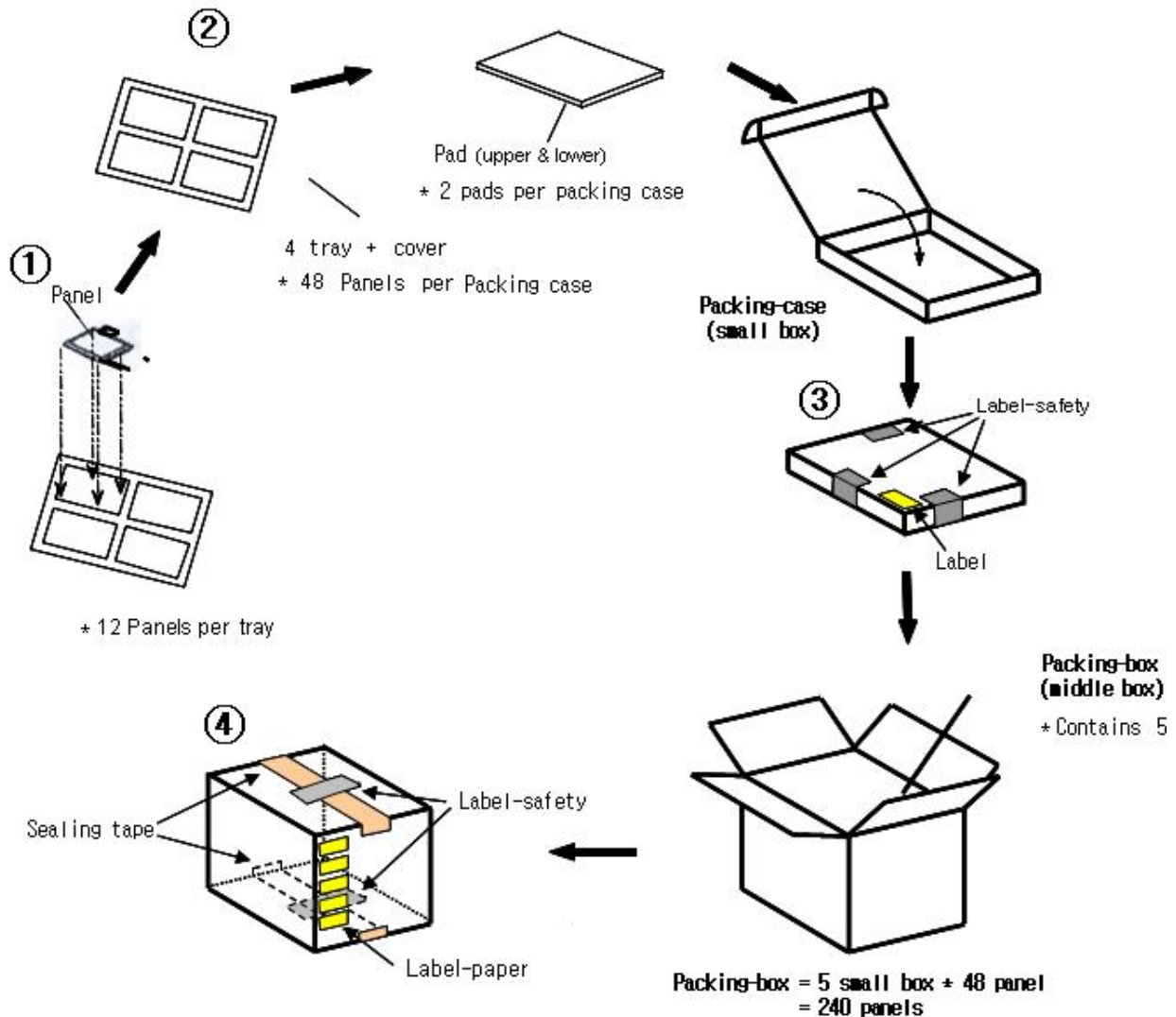

Note (1) Total : Case: Approx. 2.7 Kg

Box: Approx. 14.1 Kg

(2) Size : Case: 490(W) x 342(D) x 58(H)

Box: 505(W) x 355(D) x 312(H)

(3) Place the panels in the tray facing the direction shown in the figure.

(4) Place 5 tray and cover(empty tray) and pads inside the packing-case.

(5) Place 5 packing-case inside the packing-box.(Affix the label)

(6) Seal the packing-box. Affix the label-safety.

12. Marking & Others

(1) Packing case attach

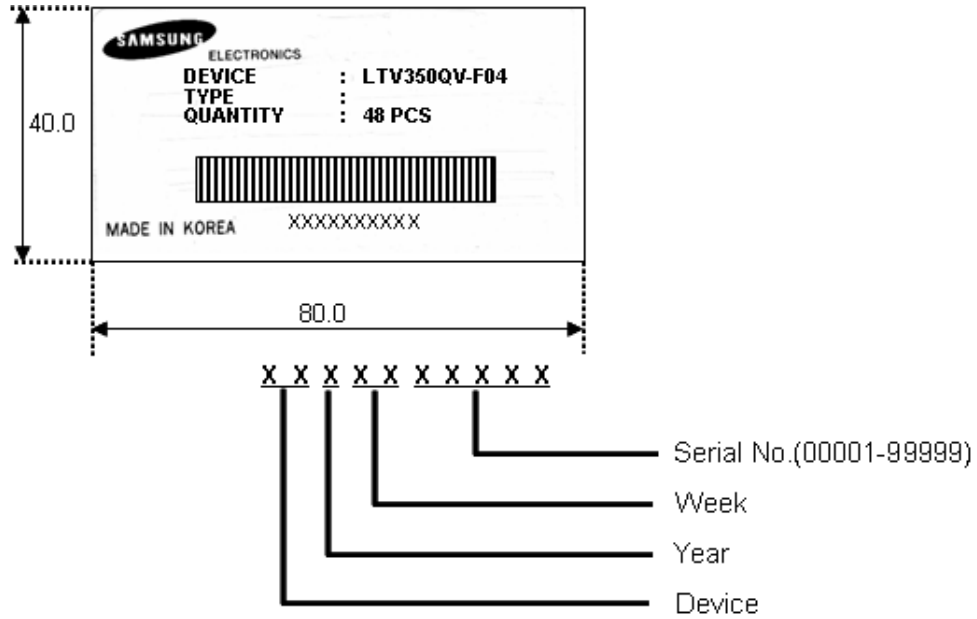

13. General Precautions

13.1 Handling

- (a) When the module is assembled, it should be attached to the system firmly. Be careful not to twist and bend the module.
- (b) Refrain from strong mechanical shock and / or any force to the module. In addition to damage, this may cause improper operation or damage to the module and back-light unit.
- (c) Note that polarizers are very fragile and could be easily damaged. Do not press or scratch the surface harder than a HB pencil lead.
- (d) Wipe off water droplets or oil immediately. If you leave the droplets for a long time, Staining and discoloration may occur.
- (e) If the surface of the polarizer is dirty, clean it using some absorbent cotton or soft cloth.
- (f) The desirable cleaners are water, IPA(Isopropyl Alcohol) or Hexane. Do not use Ketone type materials(ex. Acetone), Ethyl alcohol, Toluene, Ethyl acid or Methyl chloride. It might permanent damage to the polarizer due to chemical reaction.
- (g) If the liquid crystal material leaks from the panel, it should be kept away from the eyes or mouth. In case of contact with hands, legs or clothes, it must be washed away thoroughly with soap.
- (h) Protect the module from static , it may cause damage to the Integrated Gate Circuit.
- (i) Use finger-stalls with soft gloves in order to keep display clean during the incoming inspection and assembly process.
- (j) Do not disassemble the module.
- (k) Protection film for polarizer on the module shall be slowly peeled off just before use so that the electrostatic charge can be minimized.
- (l) Pins of I/F connector shall not be touched directly with bare hands

13.2 Storage

- (a) Do not leave the panel in high temperature, and high humidity for a long time. It is highly recommended to store the module with temperature from 0 to 35°C and relative humidity of less than 70%.
- (b) Do not store the TFT-LCD module in direct sunlight.
- (c) The module shall be stored in a dark place. It is prohibited to apply sunlight or fluorescent light during the store.

13.3 Operation

- (a) Do not connect, disconnect the module in the "Power On" condition.
- (b) Power supply should always be turned on/off by the "Power on/off sequence"

13.4 Others

- (a) The Liquid crystal is deteriorated by ultraviolet, do not leave it in direct sunlight and strong ultraviolet ray for many hours.
- (b) Avoid condensation of water. It may result in improper operation or disconnection of electrode.
- (c) Do not exceed the absolute maximum rating value. (the supply voltage variation, input voltage variation, variation in part contents and environmental temperature, and so on) Otherwise the panel may be damaged.
- (d) If the panel displays the same pattern continuously for a long period of time, it can be the situation when the image "Sticks" to the screen.
- (e) This panel has its circuitry FPC on the bottom side and should be handled carefully in order not to be stressed.